

## Notching and Drilling

In running cable for integration projects, it is necessary to notch and drill holes to allow the cable to be strung through the framework of the home. To maintain the integrity of the structure, it is imperative to follow certain notching and drilling practices.

### Drilling Wall Studs

When drilling a hole through a stud, the edge of the hole must not be closer than 5/8" from the edge of the stud. If the hole edge is within 1 1/4" from the edge of the stud a nail plate should be used. If the hole is drilled in a non-load bearing wall, the hole must not exceed 60% of the depth of the stud. For a load bearing wall a hole cannot exceed 40% of the depth of a stud.

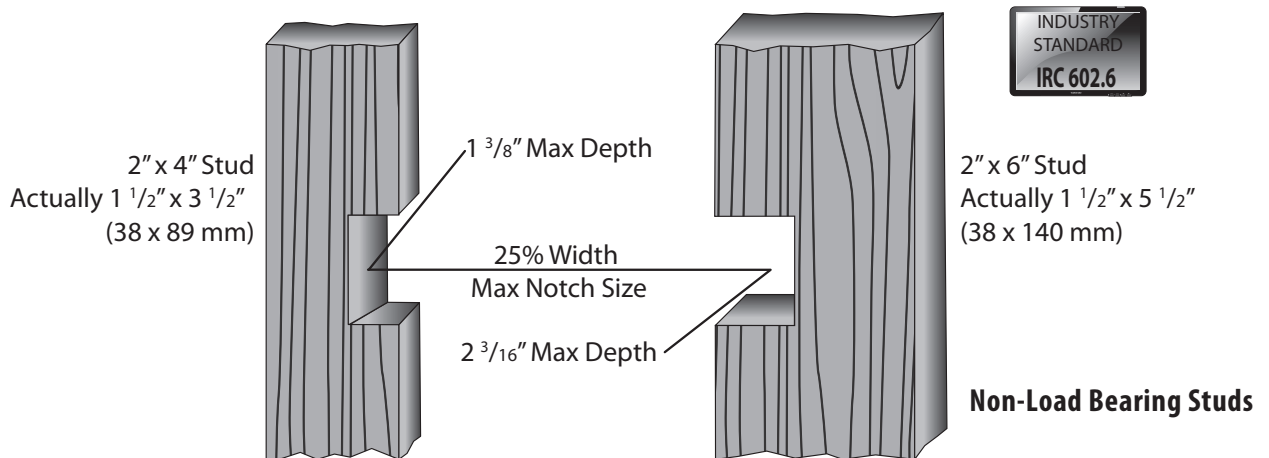

### Notching Wall Studs

A load bearing stud may be notched to a depth of 25 percent of the stud's width and anywhere along the length of the stud, except when back to back to a drilled hole or notch. A non-load bearing stud may be notched to a depth of 40 percent of the stud's width.

## Drilling Joists and Rafters

Drilling joists and rafters is covered by IRC R502.8.1 and R802.7.1. Holes are not permitted within 2 inches (50 mm) of the edges of the joists and rafters. In addition, a hole must not be larger than 1/3 the depth of joist or rafter. Holes can be drilled anywhere along the length of the joist or rafter.

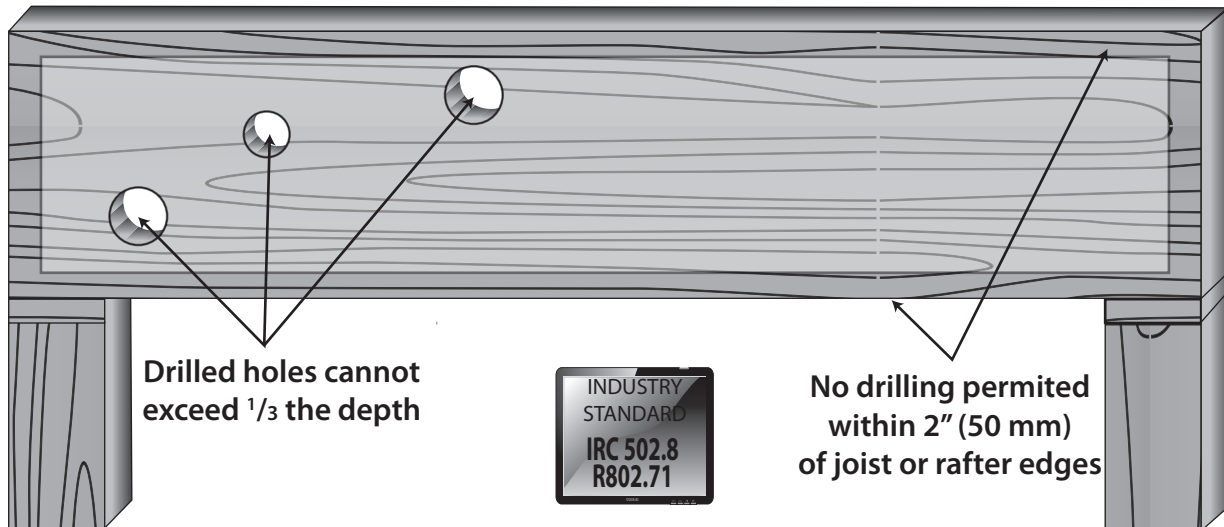

## Notching Joists and Rafters

Notching joists and rafters is covered by IRC R502.8.1 and R802.7.1. The size (depth) of the notch varies with the span of the joist or rafter. Notches along the edge of the joist or rafter must not exceed 1/6 the depth, and must not be located in the middle third of the joist or rafter.

## Nail Plates

Nail plates, also known as notch plates, are installed over a notch or a hole where the cable is within 1 1/4" of the face of the stud. The plate must be at least 1/16 inch (1.6mm) thick and cover the entire cable as it passes through the stud. This is covered by NEC 300.4. As a result of the plate, a nail or screw will not be able to penetrate the cable.

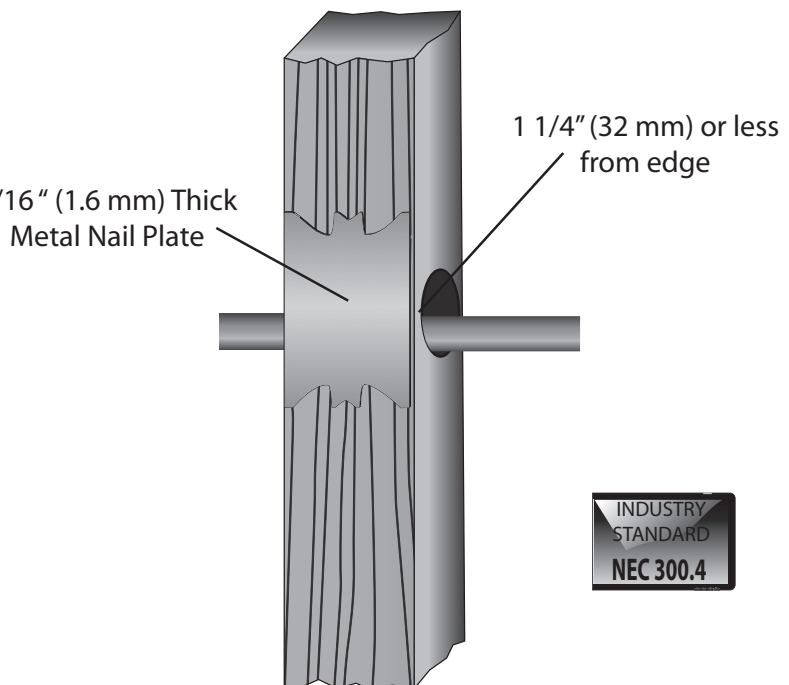

Copyright ©2007 by Dpartner. No part of this article may be reproduced, stored in a retrieval system, or transmitted in any form, or by any means, electronic, mechanical, photocopying, recording, scanning, or otherwise, except as permitted under Section 107 or 108 of the 1976 United States Copyright Act, without prior written permission of Dpartner. Trademarked names may appear in this book. Rather than use a trademark symbol with every occurrence of the trademarked name, we use the name only in an editorial fashion and to the benefit of the trademark owner, with no intention of infringement of the trademark. The information in this article is distributed on an "as is" basis, without warranty. Although every precaution has been taken in the preparation of this work, neither the authors nor Dpartner shall have any liability to any person or entity with respect to any loss or damage caused or alleged to be caused directly or indirectly by the information contained in this article.



**PARTNER**  
5020 Fairways Circle, Unit 205  
Vero Beach, FL 32967  
772.539.9433  
www.Dpartner.com